



GED 25/1001 SHORT CATALOG

- POWER QUALITY MANAGEMENT
- POWER FACTOR CORRECTION
- ENERGY MANAGEMENT IoT PLATFORM
- METERING AND PANEL ACCESSORIES
- SWITCHES AND FUSES
- SYSTEM FOR TIME AND LIGHT
- KNX SYSTEM
- CABLE MANAGEMENT SYSTEM
- LIGHTNING PROTECTION

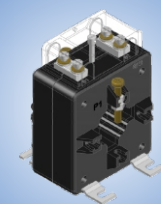

TABLE OF CONTENT

SHORT CATALOG	Page
POWER QUALITY MANAGEMENT (GAE)	1
Active Harmonic Filters (AHF)	1
Static Var Generator (SVG).....	1
POWER QUALITY MANAGEMENT (MERUS)	3
Active Harmonic Filters	3
POWER FACTOR CORRECTION (GAE)	5
Automatic Power Factor Correction	5
Capacitor, Contactor for Capacitor, Reactor 415 V, Power Factor Regulator	6
ENERGY MANAGEMENT lot PLATFORM (GAE)	8
Energy Management lot Platform	8
EMG Series Multifunction Power Meter	8
Gateway Series	9
METERING AND PANEL ACCESSORIES (GAE)	10
Metering	10
GEO Metering	10
Phase Failure Relay and Water Level Control	10
Low Voltage Current Transformer	11
LOAD BREAK SWITCHES (SENZO BY GAE)	12
LCS SERIES	12
Senzo Automatic Transfer Switches.....	13
SWITCHES AND FUSES (GAE)	14
Modular Switch Disconnectors SD1 - SD3, Load Break Switches.....	14
Change-Over Switches, Motorized Change-Over Switches	14
NT Fuse and Fuse Holders, Cylindrical Fuses, Fuse Switch Disconnectors.....	15
SYSTEM FOR TIME AND LIGHT (THEBEN)	16
Analog Time Switch.....	16
Digital Time Switch.....	16
Hour Counter	16
Lux Sensor	16
Motion Detector.....	16
Presence Detector.....	16
KNX SYSTEM (THEBEN)	17
KNX System	17
DIGITAL TIME SWITCH (SENZO BY GAE)	18
DT116	18
MOTION SENSOR (SENZO BY GAE)	19
SENS MS-8	19
CABLE MANAGEMENT SYSTEM (PANASONIC)	20
Panasonic White Conduit and Accessories, Conduit Fittings	20
Polyethylene- lining Steel Pipe, Flexible and Accessories	20
CABLE MANAGEMENT SYSTEM (SENZO BY GAE)	21
White Steel Conduit and Conduit Fittings	21
ZAM Steel Conduit	21
CABLE LUG (SENZO BY GAE)	22
Cable Lug Light	22
CABLE LUG (GAE)	22
Cable Lug Heavy (GAE), Bimetal Long Palm Lugs (GAE), Press Connector (GAE)	22
LIGHTNING PROTECTION (FRANKLIN FRANCE)	23
Saint-Elme Series, Lightning Conductor	23
Lightning Counter, Earthing Equipment, GIM Grounding Improvement Material	23
SURGE PROTECTION DEVICE (GAE)	24
4 Pole Surge Protection Device.....	24
2 Pole Surge Protection Device.....	24

GC-Series



AHF Free Standing Panel



AHF Rack Mounted



AHF Wall Mounted

The 3-Level Topology Design

GAE Active Harmonic Filter uses the latest generation 3-level Topology Active Harmonic Filter that incorporates many unique and innovative design features.

Generally installed in free standing cabinet or wall mounted modules, the 3-Level Topology has the following main features:

- Fast response time, 20kHz high IGBT switching frequency.
- Improve system voltage resistance.
- Dynamic real time compensation, not affected by system imbalance.

Harmonics Compensation Capability

Compensates 2nd to 50th harmonic order or simultaneous compensation or all 50 harmonic orders.

Algorithm Intelligence

Intelligent technology that integrates both FFT and Dynamic Compensation Modes, customized to the client's requirements.

Load Balancing and Reactive Power

Active Harmonic Filter is capable of measuring each phase and then redirecting the existing load current to balance the phases. They are also capable of using their remaining capacity to dynamically inject reactive power to correct the power factor. It is possible for the user to program the unit to prioritize load balancing or reactive power, depending on the application.

GAE - STATIC VAR GENERATOR (SVG)

Static Var Generator Main Function

- Compensation for capacitive and inductive reactive power
- Compensation for 2nd to 13th order harmonics
- Three-phase unbalance correction

SVG Operating Principle

Static Var Generator (SVG) monitors the real time load current from external Current Transformer, and through the internal DSP calculation to analyze the reactive current, and then set this value to control the PWM signal to IGBT inverter device to meet the requirements of the reactive power compensation current.

GAE - AHF/SVG TECHNICAL DATA SHEET

Item	Name	Description
Specification	AHF Size/Capacity	10, 15, 30, 50, 75, 100, 150, 200 A
	SVG Size/Capacity	7.5, 20, 30, 50, 75, 100, 150 kVar
	Rated Voltage	380V/400V (± 20%)
	Power Grid Frequency	50Hz/60Hz (Range: 45Hz - 62.5Hz)
	Wiring System	3P3W/3P4W
Function	Harmonic Filtering	2 nd ~ 50 th (AHF), 2 nd ~ 13 th (SVG)
	Reactive Power Compensation	Adjustable from -1 to +1
	Unbalance Correction	100% imbalance correction
	Protection Function	Over-voltage, under-voltage, over-heat, over current, short-circuit, inverter bridge inverse protection, over-compensation protection etc., more than 20 kinds of protection
Technical Parameter	Current Transformer	150/5A ~ 6000/5A
	Harmonic Filter Rate	≥97%
	Noise Level	<60dB
	Reaction Time	<50μs
	Full Response Time	<10ms
	IGBT Switching Frequency	20kHz
	Topology Design	3 Level Topology
	Parallel Quantities	Unlimited
Communication & Monitoring	Communication Port	RS485 Communication & Modbus
	Communication Protocol	Modbus Protocol / Optional Ethernet
	Module Display Interface	4.3" LCD touch screen (Wall mounted) or 10" LCD touch screen (Parallel Rack Mounted)
	Monitoring	Independent monitoring and centralized monitoring
Mechanical parameter	Mounting Type	Wall Mounted / Rack Mounted / Free Standing panel
	Altitude	≤1500m. Between 1500m to 4000m, derating by 1% for every additional 100 m.
	Relative Humidity	5% to 95% non-condensing
	Operating Temperature	-10°C ~ 45°C
	Ingress Protection class	IP 20
	Standard Compliance	IEC 61000/62477

ACTIVE HARMONIC FILTERS

Power quality and its solutions

Power quality is becoming a critical issue in electrical environments as industry, automation and machinery are constantly increasing. Every day, more variable frequency drives (VFD) and other non-linear loads are being connected to electrical networks. They get more sensitive to poor power quality issues that they often generate themselves. Poor power quality can cause severe economic and technical issues.

Typical power quality problems are:

- **Overheating of equipment**
- **Poor performance and malfunctions**
- **Decreased lifespan of devices**
- **System heat losses**
- **Overdimensioning of the electrical feeder**
- **Power cuts**



A2 Module Series In Cubick

Most of the countries worldwide have power quality standards and recommendations in place, such as IEEE519, G5/4 and EN 50160. These require the power quality to be always kept within the prescribed range in order for electrical systems to function in their intended manner without any issues.

Basically, power quality issues can be divided into three main categories:



HARMONICS



REACTIVE POWER



UNBALANCE



Merus A2 Module

Merus™ A2-Active Harmonic Filters operate similarly to noise-canceling headphones. They measure the distorted current of the non-linear load and inject harmonic frequencies, but with an opposite phase angle. Canceling out harmonic currents reduces voltage harmonics and eliminates distortion at the point of common coupling.

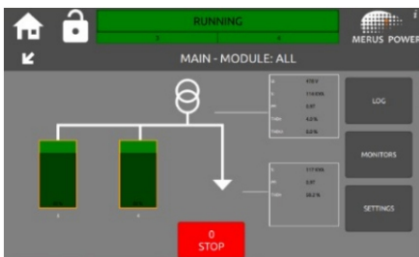

Smart and Advanced HMI

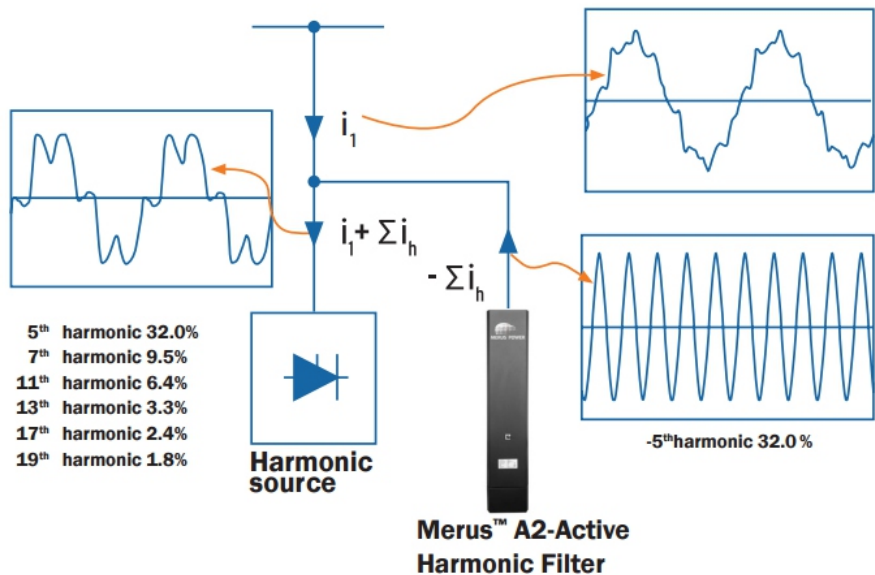

ACTIVE HARMONIC FILTERS

TECHNICAL DATA FOR CORE PRODUCTS

Nominal current capacity	50 A	100 A	150 A	200 A
Nominal voltage	3W configuration: 200 VAC – 480 VAC ($\pm 10\%$), 4W configuration: 200 – 440 VAC ($\pm 10\%$) higher voltages with suitable step-up transformer			
Harmonics filtering	2 nd to 50 th harmonics. Fully selectable and programmable up to 25 th harmonic order in 'selectable' mode (standard deliveries).			
Interharmonic filtering	Interharmonics are filtered up to the 50 th harmonic order when operating in 'all harmonics' or 'all harmonics but not fundamental' modes.			
Filtering performance	Typically, <5% THDi even with the most complex loads. <3% THDi reachable (reduction with load harmonic above 50% module rating and the nonlinear load has >3% inductive impedance)			
Operation modes	All harmonics/All harmonics but not fundamental/Selectable harmonics			
Reaction / Response time	Reaction time <50 μ s / Response time <100 μ s (1 network cycle in selectable mode)			
Parallel modules	Unlimited scalability. Load is shared evenly between parallel modules			
Switching frequency	20 kHz			
Controller	Real time digital control with FFT			
Redundancy	Each module has independent controller. If one module fails, the rest keep operating			
Load balancing capacity	Programmable 0...100% * IN of the module			
Max neutral wire current	150 A	300 A	450 A	600 A
Network (3-wire/4-wire)	3W/4W			
HMI / display	7" touch screen with multilingual graphical HMI			
Connections for HMI	1...7 module connections in one HMI. Unlimited number of HMIs			
HMI languages	English-German-Spanish-Chinese (T)-Chinese (S)-Russian-Japanese-Turkish-Polish. Others on request.			
Monitoring and reporting	On-site and remote monitoring capabilities Waveforms and spectrums from both load and network sides Trend charts			
Communication capability	Ethernet, USB, Modbus TCP/IP			
Cooling method	Forced air by temperature-controlled fans			
Protection degree	IP 20, up to IP54 depending on the enclosure Pollution degree 2 Conformal coating on all PCBAs			
Temperature	5-40 °C, without derating. Max ambient temperature 50 °C			
Humidity	Maximum 85% RH, non-condensing (operation) Maximum 95% RH, non-condensing (storage)			
Losses	<2.3%			
Dimension (WxDxH)	225x500x850 mm ³	225x500x850 mm ³	225x500x1150 mm ³	225x500x1150 mm ³
Weight	70 kg	70 kg	110 kg	110 kg
Main cable entry	Top/Bottom			
Typical noise at full load	60 dB	64 dB	67 dB	68 dB
CT locations	No audible switching frequency noise Network/load side			
Number of CT's	3 pcs / 6 pcs			
CT polarity change	Installed CT polarity can be changed without HW changes in the network			
Minimum CT accuracy class	1.0 or better			
CT-primary/secondary	Primary: no limitations. Secondary: load currents: 1A/5A, auxiliary currents: 5A.			
Ventilation requirements	300mm free space below and above the module required for air ventilation			
External fuses (recommendation)	NH 00 gL/gG 63A	NH 00 gL/gG 125A	NH 01 gL/gG 200A	NH 01 gL/gG 250A

AUTOMATIC POWER FACTOR CORRECTION

Automatic Power Factor Correction, typical for large electrical systems with fluctuating load where it is common to connect a number of capacitors to a main power distribution station or substation. The capacitors are controlled by a microprocessor based relay which continuously monitors the reactive power demand on the supply.

The installation of detuned (reactor-reconnected) capacitors is designed to force the resonant frequency of the network below the frequency of the lowest harmonic present, there by ensuring no resonant circuit end, by implication, no amplification of harmonic current. Such an installation also has a partial filtering effect, reducing the level of voltage distortion on the supply, and is recommended for all cases where the share & non linear loads is more than 10% of the rated transformer power.

Full set of essential component for capacitor bank.



THE HEART
Capacitors.
Without them, RFC is impossible.
They are the most sensitive and most important component.



THE MUSCLE
Switching is one of the key function in your RFC, and switching capacitors means maximum stress.



THE PROTECTION
Most RFC nowadays cannot do without detuning reactors for harmonic protection anymore.



THE BRAIN
The controller shall know what to do, and when.

CAPACITOR

Output Capacity KVAR	Phase	Volt
Single Phase Modular MKP Type		
1.8	1	415
Single Phase Modular MKP-c Eco Series		
3.3	1	415
4.17	1	415
Three Phase Modular MKP-c Eco Series		
2.5	3	415
5	3	415
MKP-c Eco Series type, 480 Volt Qn (kVar)		
Phase	@415	@480
3	25	33.4
MKP-c Eco Series type, 440 Volt Qn (kVar)		
Phase	@415	@440
3	10	11.2
3	12.5	14
3	15	16.8
3	20	22.4
3	25	28.1
3	30	33.7
3	40	44.9
3	50	56.2

MKP- c Eco Series Type, 525 Volt Qn (kVar)		
Phase	@415 V	@525 V
3	12.5	20
3	15.6	25
3	25	40
3	31.2	50
Three Phase Modular MKPg, 415 Volt		
Phase	@415 V	
3	15	
3	20	
3	25	
3	30	
3	40	
3	50	
MKPg Type, 525 Volt Qn (kVar)		
@415 V	@525 V	
12.5	20	
25	40	

CONTACTOR for CAPACITOR

220 - 240 V kvar		400 - 440 V kvar	
	8.5		16.7
	10		20
	15		25
	20		33.3
	25		40
	27		50
	40		60
	45		75
	60		100

REACTOR 415 V

BLOCKING REACTOR 7%

12.5 kVar	31.2 kVar	75 kVar
15.6 kVar	50 kVar	93.6 kVar
25 kVar	62.4 kVar	100 kVar

POWER FACTOR REGULATOR

- Fully Automatic Regulator 6 step, 12 step and 14 step
- No Required to adjust c/k value

Table comparison between BLR GAE and RCG GAE

	BLR CX GAE	RCG GAE
Step number	6 / 12 / 14	12
Display	LCD	LCD
Measurement type	IP	IP
Basic measurement	Yes	Yes
Power quality measurement	Yes	Yes
	- Individual harmonics up to 31 - THD V, THDI	- Individual harmonics up to 51 - THD V, THDI
Digital input and digital output	No	Yes
Alarm relay output	No	Yes
Modbus communication (RS 485)	No	Yes
Free software monitoring	No	Yes



Advantage of Energy Management

- Enable predictive maintenance and effective working
- Intervene failures quickly and minimize stop periods
- Analyzed energy networks and minimize machinery faults caused by energy quality
- Design report templates, analyze and report data automatically
- Quickly access to historic data and compare to see your progress in energy efficiency
- Monitor and access to your system from anywhere through any device connected to the internet.



Web Based System

Users can gain access to the system regardless of the platform, simply through a standard web browser.



Modular Structure

Modular structure enable various expansion according to the needs of the customers.



Advanced Database

Advanced database features enable detailed device monitoring, parameter logging, analyzing and reporting.



Time Zone Support

Different time zone can be defined for the devices located at different regions with time zone support.



Security

HTTPS support, user password, function and profile based user authorization ensures a high-level system safety.



Load Share

Number of device that communicate is infinite with load share, a single server support more than 2.000 devices.

You can make real-time monitoring and see instant data from the system using main GAenergy monitoring module. It is possible to expand and add features to the GAenergy platform according to your needs.

Monitoring

You can get access to real-time device parameter and instant device data from anywhere with GEN fully-customizable monitoring module.

Reporting

It is possible to access all historic data, search for a specific time period, design custom reports and automate reporting and invoicing activities.

Alarm Management

Alarm parameters can be set for all devices within the system, the systems logs alarm data with timestamp. All alarm activities can be monitored and managed through the system.

Map Screen

Enables over-the-map monitoring of devices located at different facilities or regions by simply pinning devices on the map.

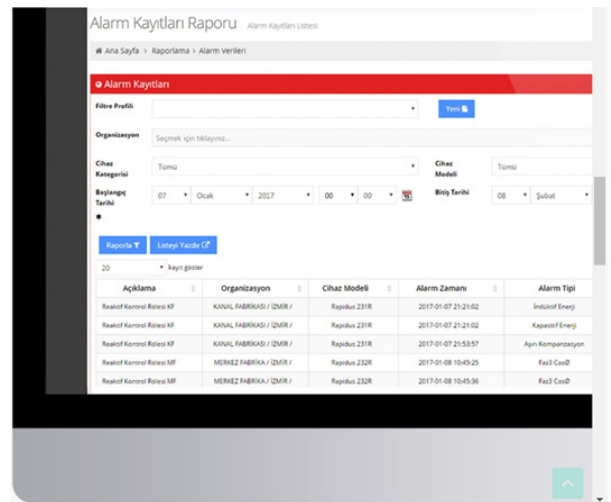

Advanced Reporting

All parameter logged in real-time and can be displayed as table or graph data as needed.

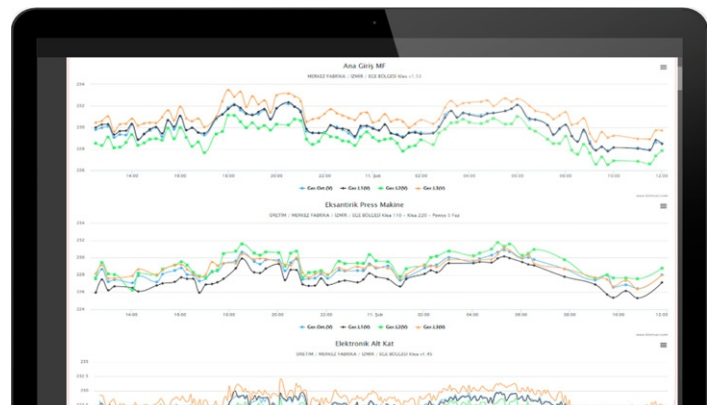

EMG SERIES MULTIFUNCTION POWER METER

EMG 5

EMG 10

EMG 20B

EMG 25

EMG 50
1 - GENERAL SPECIFICATIONS

Type	EMG 5	EMG 10	EMG 20B	EMG 25	EMG 50
Definition	3 Φ Multimeter	3 Φ Multimeter	3 Φ Energy Analyzer	3 Φ Energy Analyzer	3 Φ Energy Analyzer
Display	Seven Segment	Seven Segment	LCD	LCD	LCD
Data Logging with Timestamp	-	-	-	-	●
CTR & VTR (1-5000 adj.)	●	●	●	●	●
Demand Period (1-60 min adj.)	-	●	●	●	●
Number of Measurement in a period	256	256	256	256	512
Phasor Diagram	-	-	-	-	●
Signal Waveforms	-	-	-	-	●
RS485 Communication	-	-	●	●	●

2 - AUXILIARY POWER

Range	85 - 300 VAC/DC	85 - 300 VAC/DC	85 - 300 VAC/DC	85 - 300 VAC/DC	85 - 300 VAC/DC
Power Consumption	<3 W, <6 VA	<3 W, <6 VA	<2 W, <4.5 VA	<2 W, <4.5 VA	<2.5 W, <3 VA

3 - MEASUREMENT

Basic Measurements (V, I, f, Cos Φ , PF, P, Q, S, THDI, THDV, etc.)	only V, I, f	●	●	●	●
Min, Max and Demand Values	-	●	●	●	●
Current Measurement Input	10mA - 6A AC	10mA - 6A AC	10mA - 6A AC	10mA - 6A AC	10mA - 6A AC
Voltage Measurement Input	1 - 300 VAC (L-N)	1 - 300 VAC (L-N)	1 - 300 VAC (L-N)	1 - 300 VAC (L-N)	1 - 300 VAC (L-N)
	2 - 500 VAC (L-L)	2 - 500 VAC (L-L)	2 - 500 VAC (L-L)	2 - 500 VAC (L-L)	2 - 500 VAC (L-L)
Harmonics for Current and Voltage Phases	-	-	Up to 31st	Up to 31st	Up to 51st
THD for Voltage and Current in	-	●	●	●	●

4 - MEASUREMENT ACCURACY

Total Active Power	-	0.5	0.5	0.5	0.2
Total Reactive Power	-	1	1	1	1
Total Apparent Power	-	0.5	0.5	0.5	0.2
Total Active Energy	-	0.5	0.5	0.5	0.5
Total Reactive Energy	-	2	2	2	2
Frequency	0.1	0.1	0.1	0.1	0.05
Current	0.5	0.5	0.5	0.5	0.2
Neutral Current	-	0.5	0.5	0.5	0.5
Voltage	0.2	0.2	0.2	0.2	0.2
Power factor	-	0.5	0.5	0.5	0.5
THDV, THDI	-	1	1	1	1

5 - ENERGY METERS AND COUNTERS

Tariff	-	Utility	Utility	Utility & Genset	Utility & Genset
Multi Sub-Tariffs (Peak, Day and Off-Peak)	-	-	-	-	●
3 Φ Phase Energy Meters	-	●	●	●	●
On Hour, Run Hour and Int Counter	-	●	●	●	●

EMG SERIES MULTIFUNCTION POWER METER

6 - INPUTS AND OUTPUTS					
Alarm Relay Outputs	-	-	-	2 pcs. (10A,250VAC,1250VA)	2 pcs. (10A,250VAC,1250VA)
Digital Inputs	-	-	-	2 pcs. (Dry Contact)	2 pcs. (Dry Contact)
Digital Outputs	-	-	-	2 pcs. (5-30VDC)	2 pcs. (5-30VDC)
7 - COMMUNICATION					
Protocol	-	-	Modbus RTU	Modbus RTU	Modbus RTU
Baud Rate	-	-	1200-57600 bps adj.	1200-57600 bps adj.	2400-115200 bps adj.
LEGEND:					
● feature supported	bit.ly/GAEemg5	bit.ly/GAEemg10	bit.ly/GAEemg20b	bit.ly/GAEemg25	bit.ly/GAEemg50

GATEWAY SERIES



ETG 485
Ethernet to RS485 Converter

ETG

- Sleek Housing
- 300- 115.200 bps baudrate adjustment
- Easy configuration
- Quick view of status with LED



UTG 485
USB to RS485 Converter

UTG

- USB to RS 485
- 300-115.200 bps baudrate adjustment
- Isolation 2500 Vrms

METERING



Energy meter 3P kWh
Inductive Type
Voltage 3x 220/380 V,
Current .../5A or
direct 5 (20) A



Ammeter
Direct 10A-40A
or with CT.../5A



Voltmeter
Direct 250V, 500V
or with PT.../100V, 110V



Double Voltmeter
Direct 250V, 500V
or with PT.../100V, 110V



Zero Voltmeter
0 ... 800V,
for 380 - 400V



Watt meter
0... 10.000 kw with
CT.../5A



**Frequency
Pointer meter**
45- 55 Hz, 46- 54 Hz
48- 52 Hz



**Double
Frequency LED meter**
45- 55 Hz, 46- 54 Hz
48- 52 Hz



**Frequency
LED meter**
45- 55 Hz, 46- 54 Hz
48- 52 Hz



Cos φ meter
0.5 cap - 1 -
0.5 ind



**Reliable Metering
with Economic Price**



Voltmeter AC 96
GEO- V96, 0 ... 500V



Ammeter AC 96
GEO- A96,100/5A



**Frequency Meter
Pointer AC 96**
GEO- F96, 45- 55 Hz



**Maximum Demand
Ammeter AC 96**
GEO- M96.400/5A

PHASE FAILURE RELAY and WATER LEVEL CONTROL



**Phase Failure Relay
GC1100**

Connection diagram:

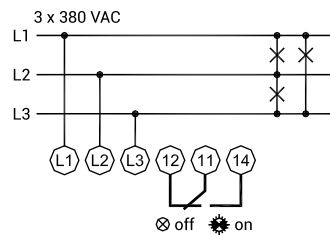

Timing diagram:

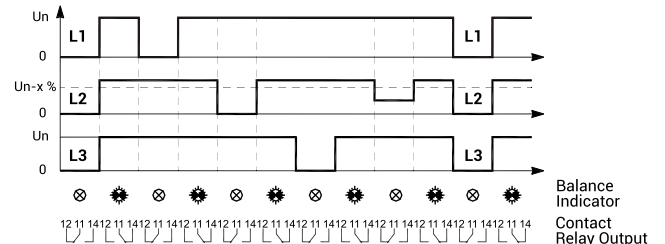

**Water Level Control
GC2200**

Figur 1

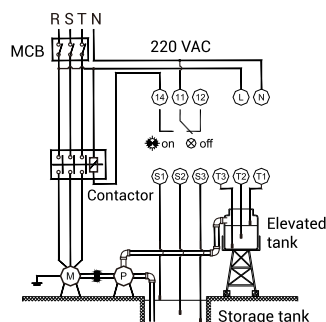

Figur 2

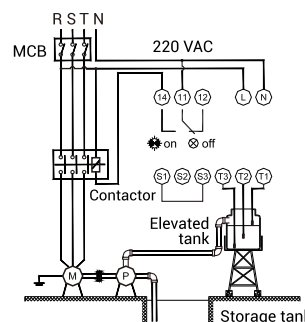

Figur 3

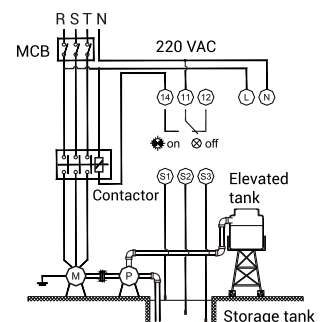

LOW VOLTAGE CURRENT TRANSFORMER



CT 50, 50/5A - 300/5A

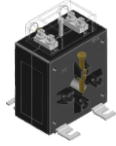

CT 60, 50/5A - 400/5A

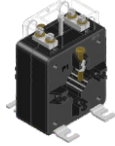

CT 70, 100/5A - 600/5A

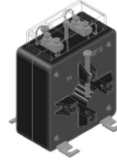

CT 71, 60/5A - 300/5A

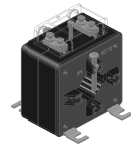

CT 72, 75/5A - 150/5A

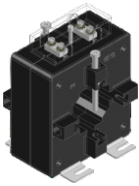

CT 110
200/5A - 1600/5A

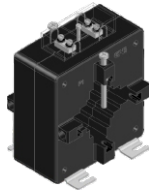

CT 150
200/5A - 2500/5A

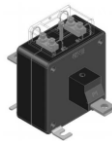

CT 101
5/5A - 50/5A



CT 102
50/5A - 150/5A

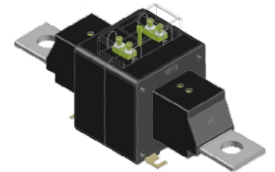

CT 103
200/5A - 300/5A



CT 201 SPLIT CORE
200/5A - 400/5A

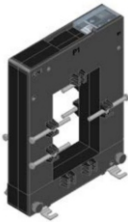

CT 202 SPLIT CORE
400/5A - 1000/5A



CT 203 SPLIT CORE
500/5A - 1000/5A

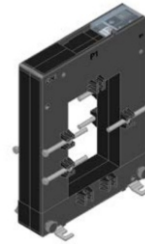

CT 204 SPLIT CORE
500/5A - 1500/5A

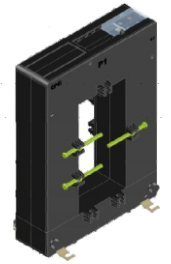

CT 205 SPLIT CORE
750/5A - 5000/5A

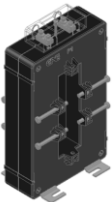

CT 301
500/5A - 3000/5A

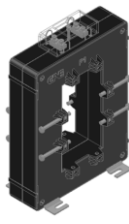

CT 302
600/5A - 4000/5A

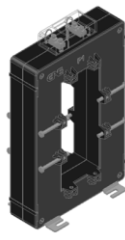

CT 303
1000/5A - 5000/5A



CT 304
4000/5A - 8000/5A



CT 41
50/5A - 100/5A



CT 42
30/5A - 100/5A



CT 43
15/5A - 100/5A

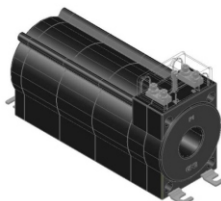

CT 44
15/5A - 100/5A

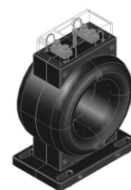

CT 403 RING
200/5A - 1600/5A

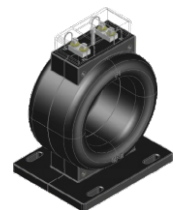

CT 404 RING
200/5A - 2500/5A



LCSeries

Load Break Switches

What Our Senzo Load Break Switches Could Offer?

- **High-quality Materials:** Ensures dependability and durability.
- **Silver-plated Contacts:** Known for excellent conductivity, handling more power without overheating.
- **Smooth Power Flow:** Keeps power flowing smoothly even in tough conditions.
- **Equipment Protection:** Handles loads with ease, protecting from unexpected failures.
- **Peace of Mind:** Provides operation continuity and reliability.

LCSERIES HIGHLIGHTS



Effortless power control with a user-friendly handle and compact design.

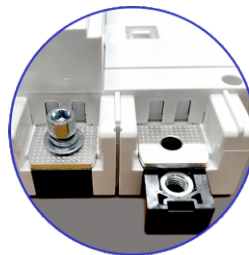

Simplify your busbar installation with our perfectly fitting, secure, and easy-to-tighten nuts.

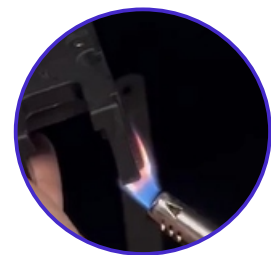

Nylon 66 reinforced material with self-extinguishing properties mitigates arcing risks, enhancing electrical system safety.

LCS Series available in: **3P** 160A 200A 250A 315A 400A 500A 630A 800A 1000A 1250A 1600A 2000A 2500A 3150A
4P

Transform your panel safety with our innovative Load Break Switches—reach out today to find the perfect model!

SENZO AUTOMATIC TRANSFER SWITCHES

Optimizing Your Power Supply

PC Class Automatic Transfer Switch



ACS 63NA || 125NA
(50A - 125A)



ACS 250NAT || 400NAT || 630NAT
(250A - 630A)



ACS 3200Q 4P
(800A - 3200A)



S700



ACS 6300Q 4P
(4000A - 6300A)

Smart Technology

Simple Installation

User Friendly

The Comprehensive Product In Same Category

Build-in Automatic Main Failure (AMF) Function

The transfer switch features **automatic phase-by-phase monitoring**, detecting **overvoltage, undervoltage, and phase loss events**.

There is no need for extra components and money to make it automatically transfer switch.

Simply install it with the included enclosure, and you'll have a full automated system at your command.

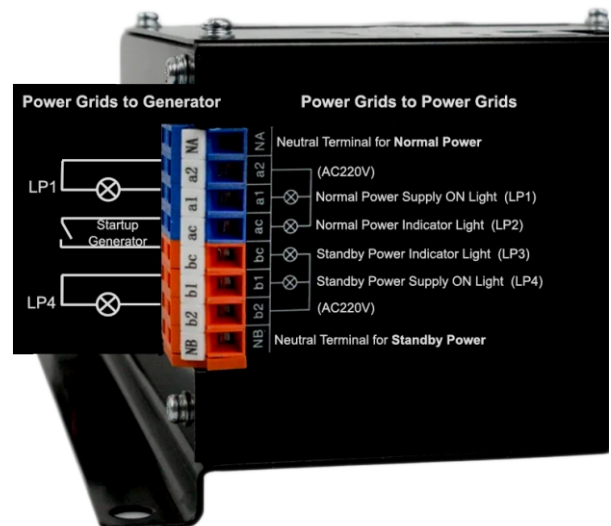

LOAD BREAK SWITCHES

Embrace the Future of Electrical Switching

Upgrade to GAE Load Break Switches for reliable electrical systems. These switches meet IEC standards, are trusted by PLN and various industries, and featuring high-quality silver-plated copper contacts with a self-extinguishing shell. Enjoy seamless power distribution with minimal risk.

Modular Switch Disconnectors



Available in: **3P**
SD1 16A - 63A
SD2 80A - 125A
SD3 160A

Load Break Switches



Available in: **3P** VC1P 160A VC4P 630A - 800A
4P VC2P 200A - 315A VC5P 1000A - 3150A
VC3P 400A - 500A

- Reliable power with GAE Load Break Switches.
- Meets IEC standards and trusted by industries.
- High-quality materials: silver-plated copper contacts, self-extinguishing shell.
- User-friendly handle and compact design.
- Affordable and ensures seamless power distribution.

CHANGE OVER SWITCHES

Enjoy a Seamless Transition

We Offer GAE Change Over Switches

- Available in Manual or Motorized versions.
- Minimal maintenance and easy installation.
- Designed for heavy-duty applications in industries, hospitals, and electric utilities.

Modular COS



Available in:
4P SD1 16A - 63A
SD2 63A - 125A

Manual Change Over Switches



Available in: **4P** CS1P 160A CS2P 200A - 315A CS3P 400A - 500A
CS4P 630A - 800A CS5P 1000A - 3150A

Motorized Change Over Switches



Available in: **4P** CS2 160A - 315A CS3 400A - 500A CS4 630A - 800A
CS5 1000A - 3150A

Trust our expertise to select the right ampere rating for your panel and ensure a seamless, reliable power transition without interruptions.

Embrace advanced electrical switching and upgrade your system

FUSES

Ensuring the Safety and Reliability

What are the common causes of blown fuses and power outages?

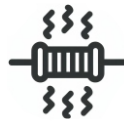

Power
Dissipation



Delayed Response
to Overload

What is our solution?

GAE NT Fuses

NT Fuse 500V/690V

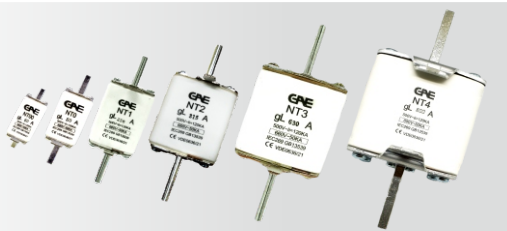

- Made with premium pure copper elements.
- Silver-plated conductors for better electrical efficiency.
- High-purity quartz sand to minimize arc effects.
- Withstands temperatures up to 1,650°C.

GAE Fuse Holders

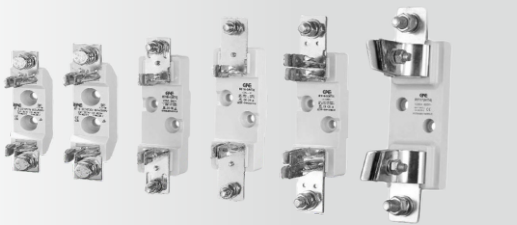

- Constructed from DMC Material.
- Flame retardant and durable in high temperatures.
- Tin-plated to prevent oxidation and corrosion.

Available in:	Size 00 6A - 160A	Size 2 200A - 400A	Available in:	Type Sist 106 160A	Type Sist 401 400A
	Size 0 50A - 160A	Size 3 355A - 630A		Type Sist 160 160A	Type Sist 601 630A
	Size 1 50A - 250A	Size 4 800A - 1250A		Type Sist 205 250A	Type Sist 1001 1000A

FUSE SWITCH DISCONNECTOR

Next-level Convenience



H2/TSL 160A - 630A



H1/3P 160A - 630A



H1/1P 160A - 630A



MRO.H2/DSL 160A - 630A

Quick Disconnection
of the circuit without removing the fuse

No Risk of Electric Harm

Isolate From Power Source
for safe maintenance or repairs

CYLINDRICAL FUSE CONTROL



- **Compact Design (10x38mm)**
for easy installation in small spaces.
- **High Breaking Capacity**
for efficient protection against high fault currents.
- **Versatile Ratings**
from 2A to 32A for various applications.
- **LED Indicators**
for easy identification of blown fuses.

ANALOG TIME SWITCH



SUL 180 a

Voltage : 220 V
 Segment : 15 min
 Power Backup : 3 days
 Frequency : 50 - 60 Hz
 Switching Capacity : LED lamp > 8 W = 300 W



SUL 181 d

Voltage : 220 V
 Segment : 15 min
 Power Backup : 3 days
 Frequency : 50 - 60 Hz
 Switching Capacity : LED lamp > 8 W = 300 W
 Time : 24 Hours

DIGITAL TIME SWITCH



SIMPLEXA SERIES

Voltage : 220 V
 Frequency : 50 - 60 Hz
 Program : Daily and weekly
 Power Reserve : 3 years (non-rechargeable)
 Switching Time : 1 min
 Keyboard : 4 four buttons and reset button
 Switching Capacity : LED lamp > 8 W = 300 W
 Memory : 42 locations



TR 610 TOP 3

Voltage : 220 V
 Frequency : 50 - 60 Hz
 Program : Daily and weekly
 Power Reserve : 10 years
 Switching Time : 1 min
 Keyboard : 4 four buttons
 Mounting Rail
 Switching Capacity : LED lamp > 8 W = 600 W
 Memory : 56 locations

HOUR COUNTER



BZ 142 - 5

Hour Counter with synchronous motor
 5 digit hour counter
 2 decimal accuracy

LUX SENSOR



LUNA 121 top3

Operating Voltage : 230V
 Brightness Range : 1 - 99000 lux
 Switching Capacity : LED lamp > 8 W = 600 W
 Features : Twilight switch with integrated weekly timer
 Adjustable switching brightness
 Adjustable on and off switching Delay
 Permanent switching ON/OFF
 Lux Reading Value
 Illuminated LCD with text line
 Protection Rating : IP 55 (AL) , IP 66 (EL), IP 20 (Luna Module)

MOTION SENSOR

General Specification

- Economic product range
- Lux sensor integration
- Available on 1 or 2 channel
- Wall mounted, ceiling mounted, flush or surface mounted
- Remote control (optional)



theLuxa S180



theLuxa S360



theMura S180



theMova S360 Flat DE

PRESENCE SENSOR

General Specification

- Square detection area
- Premium product range
- Lux sensor integration
- Self learning time delay off
- Available on 1 or 2 channel
- Ceiling mounted
- Remote control (optional)
- Master slave connection
- Short presence detection
- Smart Switching



Luxa 103 S360

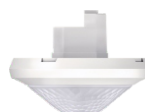

theRonda



thePrema



thePassa

KNX AUTOMATION SYSTEM

Control monitor window status

Control shutters

Push buttons or switches

KNX
Integration of e.g.

Dimming Light and LED

Scene setting

Movement & Presence Detector

KNX Display Unit

theben

The KNX Association foundation in 1990

The driving force behind KNX is KNX Association, a group of leading companies active in many fields of home and building control.

Currently, KNX Association has more than 300 members, accounting for more than 80% of the home and building control devices sold in Europe.



At a glance

KNX Actuators	KNX Sensors	KNX Controller	KNX Clocks Save clocks
-------------------------	-----------------------	--------------------------	-------------------------------------

INTEGRATION

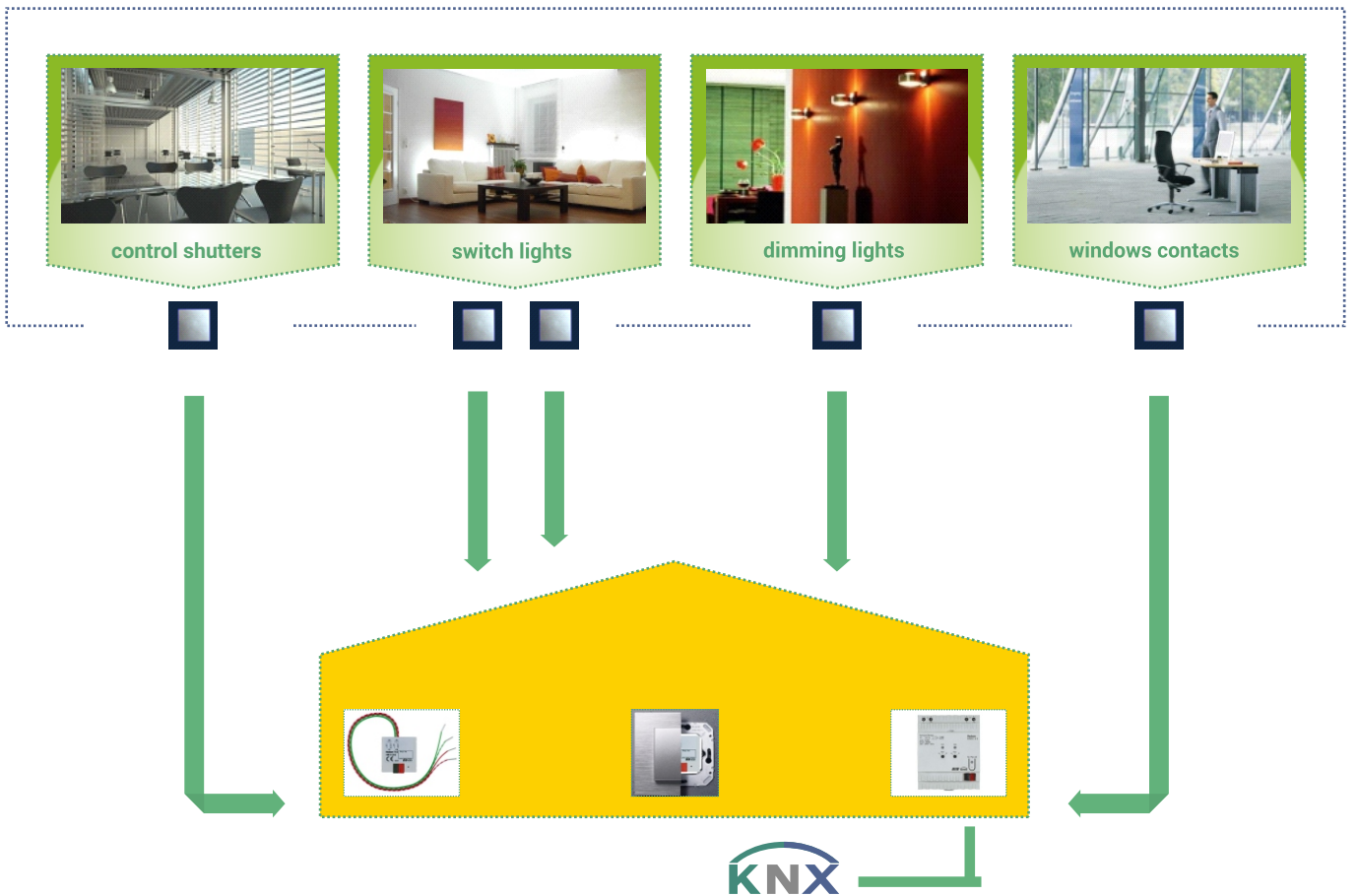

DIGITIME DT116

Digital Time Switch

- Precise time programming for Daily /Weekly /Pulse /Astro switching.
- 1 channel
- Program memory up to 50 program.
- Battery backup with 6 years battery reserve
- Solid or stranded wire
- ZCD assistance for inrush current management and for better relay & loadlife
- Holiday program
- PIN protection
- 16A maximum relay output
- 12h or 24h format
- Permanent switching ON/OFF
- Display back light



FEATURES

Why Choose Digital?



Minimum Switching Time of 1 Minute



Weekly Schedule with up to 50 Memory Slots



Larger Battery Reserve



Higher Switching Capacity



Better Security with Pin Protection

TECHNICAL DATA

Supply Characteristics		Relay Output Characteristics	
Supply Voltage (□)	240 VAC	Contact Arrangement	1 C/O
Operating Frequency	50/60 Hz	Contact Rating	16 A (NO & NC)@ 240 VAC/24 VDC (Resistive)
Supply Variations	-20 % to +10 % (Of □)	Utilization Category (AC-1)	Max switching : 16 A (NO & NC) at 250 VAC, Cos Φ = 1 Max switching: 10 A (NO & NC) at 250 VAC, Cos Φ = 0.6
Power consumption (Max)	5 VA	Incandescent Lamps	2600 W
Battery Back up	Approx. 6 Years	Halogen Lamps	2600 W
Functional Characteristics		LED Lamps	<2W: 30 W
Display	6 Lines Text LCD, Viewing Angle-6 O' Clock, Backlight- Green	LED Lamps	2W to 8W :100W
Number of Programs	50 (Each channel) + 10 Holiday (Each channel)	Electrical Life	50,000 cycles @ rated load
Clock Mode	Either 12 Hour (AM/PM) or 24 Hour Clock	Environmental Characteristics	
Clock Resolution (Min)	1 Minute	Operating Temperature	-15°C to +60°C
Pulse Duration	1-59 seconds	Storage Temperature	-20°C to +70°C
Hour Setting	00-23 for 24 Hour clock and 01-12 for 12 Hour clock	Humidity	95% Rh (Non Condensation)
Reset	Hardware reset and to be used only when device doesn't respond or hangs.	Maximum Operating Altitude	2000 m
Day Setting	Monday to Sunday	Degree of Protection	IP-20 for Terminals ;IP-40 for Enclosure
RTC Accuracy	+/- 0.5 sec/day @25°C	Enclosure	Flame Retardant UL-94 V0
Number of Keys	4 keys & 1 RESET key	Other Characteristics	
		Mounting	Din Rail
		Weight (Unpacked)	Approx. 1 Channel - 110gm

SCALE DRAWINGS

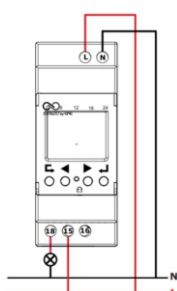

1 Channel Device

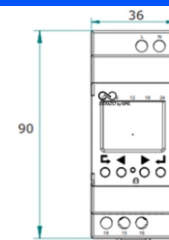
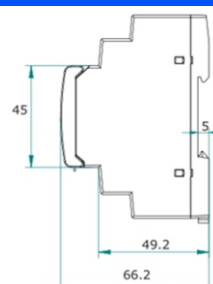
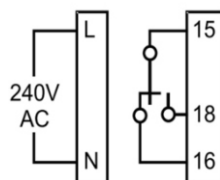

Note- All dimensions are in mm

SENS MS-8

Motion Sensor

- Unique lens design provides 360° “no blind spot” detection angle.
- Integrated sensor and power box in one unit using spring clamps for easy quick installation.
- Built-in walk test function to ensure the desired detection field is entirely covered.
- Built-in photocell allows lighting to automatic turn ON at dusk and turn OFF in daylight to achieve energy saving.
- Lens shield for minimizing or blocking detecting field as user desired.
- Large hole terminal block is used to adopt 2x2.5mm² cables for easy wiring.

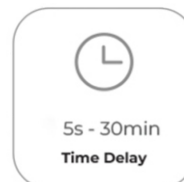

CONNECTION DIAGRAM

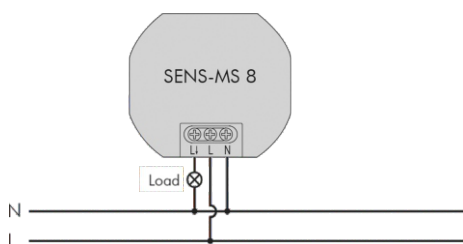

SCALE DRAWINGS

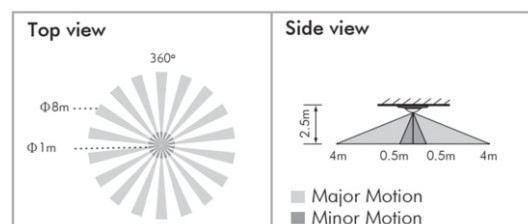
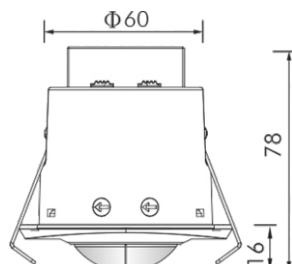
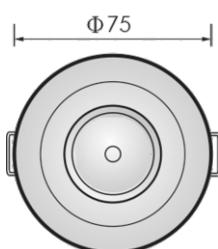

PANASONIC WHITE CONDUIT and CONDUIT FITTINGS



JIS
Plain Type E19 - E75
Thin Wall Type C19 - C75
Thick Wall Type G16 - G104



ANSI
EMT Size 1/2" up to 2"
IMC Size 1/2" up to 4"
RSC Size 1/2" up to 6"

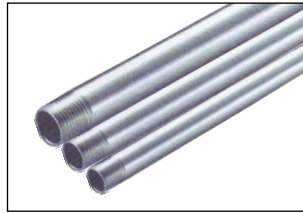

STAINLESS STEEL
IMC Size 1/2" up to 4"

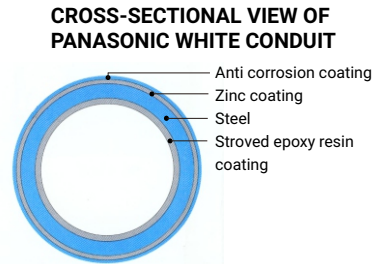

Standards

Panasonic WHITE CONDUIT is available in four types conforming to the following standard:

- UL/ANSI (EMT, IMC and RSC)
- BS (BS31-1940 and BS4568-1970)
- TIS
- JIS (Plain, Thin Wall and Thick Wall)



Coupling



Normal Bends



Bushing



Connector



Saddles Clamp



Lock Nut



Underwriters Laboratories Inc.®



JAPANESE INDUSTRIAL STANDARDS CERTIFICATION MARKING FACTORY



THAI INDUSTRIAL STANDARD

POLYETHYLENE-LINING STEEL PIPE



Non-Threaded



Threaded

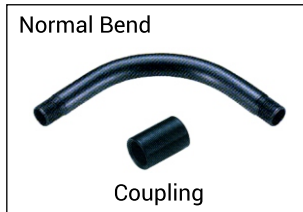

Normal Bend

Coupling

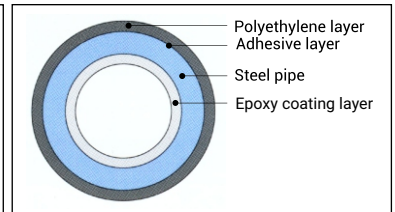

Corrosions resistant steel pipe for cable

FLEXIBLE and ACCESSORIES

(Unit: mm)

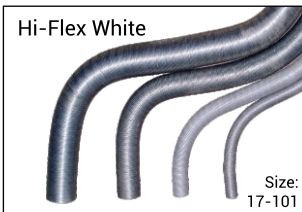

Hi-Flex White

Size: 17-101

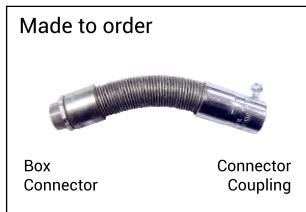

Made to order

Box Connector

Connector Coupling



Mecha Flexy + Accessories

Size 16 - 42

WP

Connection Coupling

WP

Box Connector

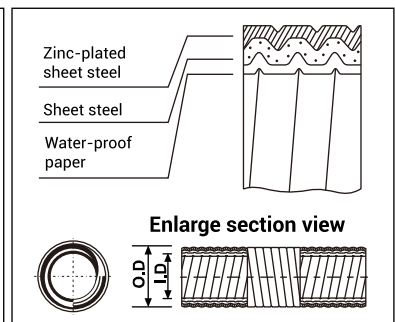

WHITE STEEL CONDUIT and CONDUIT FITTINGS

SNI (Standar Nasional Indonesia) / IEC 61386 - 21



Product Code	Size	Outside Diameter (mm)		Thickness (mm)	Length (mm)
		Min	Max		
SWI 020ZY	20	19.7	20.0	1.6	3,750
SWI 025ZY	25	24.6	25.0	1.6	3,750
SWI 032ZY	32	31.6	32.0	1.6	3,750

Material : Hot - dip galvanized steel - Class 4

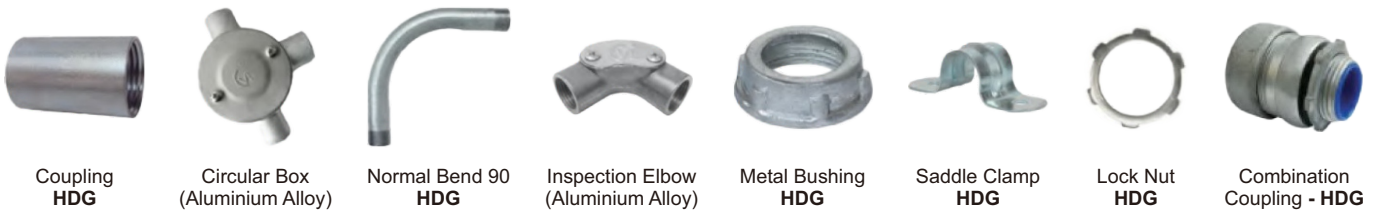

Installation pipe to box / any flat surface area



Installation combination coupling from flexible to box / any flat area

ZAM STEEL CONDUIT

ANSI Standard

ZAM refers to Zinc-Aluminium-Magnesium, a high-performance metallic coating applied to steel designed to offer superior corrosion resistance, durability, and heat resistance compared to traditional galvanizing (zinc-only coatings). ZAM is superior corrosion resistance compared to hot-dip galvanized steel. Adding aluminum increases the coating's resistance to high temperatures and oxidation, while magnesium improves its resistance to corrosion in harsh environments like coastal, industrial, and chemical settings. ZAM has self-healing properties—if the coating is damaged, the magnesium component reacts with moisture to help prevent further corrosion.



Product Code	Size	Min.Thickness (mm)
EMT 012ZA	1/2"	1.02
EMT 034ZA	3/4"	1.18
EMT 100ZA	1"	1.37

Material : Steel with ZAM Coating



Product Code	Size	Min.Thickness (mm)
IMC 012ZA	1/2"	1.79
IMC 034ZA	3/4"	1.90
IMC 100ZA	1"	21.6

Material : Steel with ZAM Coating

SENZO CIRCULAR BOX

JIS / ANSI Standard

SENZO by GAE Circular Box, manufacture locally in Semarang, Indonesia. With our expert in manufacture and product, we deliver the best local product for Circular Box.

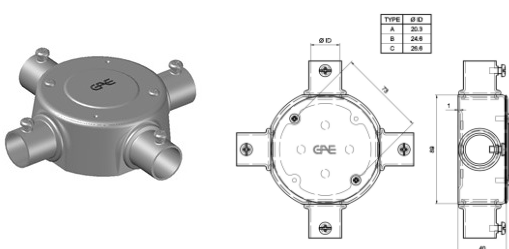

Type
1 Way
2 Way Straight
2 Way Angle
3 Way
4 Way

Standard	
JIS	ANSI
E - Type	EMT - Electrical Metallic Tube
C - Type	IMC - Intermediate Metal Conduit
G - Type	RSC - Rigid Steel Conduit

CABLE LUG (SENZO BY GAE)

NEW PRODUCT



Light Type	: 4 - 500 mm ²
Material	: Copper
Finishing	: Tin Plated
Composition of Copper	: ≥ 99.92%
Electrical Conductivity	: ≥ 98%
Tensile Load	: ≥ 250N
Class	: A

CABLE LUG (GAE)



Heavy Duty Type	: 2.5 - 500 mm ²
Material	: Copper
Finishing	: Tin Plated
Composition of Copper	: ≥ 99.92%
Electrical Conductivity	: ≥ 98%
Tensile Load	: ≥ 250N
Class	: A

BIMETAL LONG PALM LUGS (GAE)



Conductor Cross Section Area (mm ²)	: 1 Hole Palm (25 - 150 mm ²), 2 Holes Palm (25-150 mm ²), 3 Holes Palm (120-800 mm ²)
Copper Composition	: Cu+Ag 99.9%, Bi 0.001%, Sb 0.002%, As 0.002%, Fe 0.005%, Pb 0.005%, S 0.005%
Aluminum Composition	: Al:99.7%, Si:0.20%, Fe: 0.25%, Cu:0.04%, Mn:0.03%, Mg:0.03%, Zn:0.04%, Ti:0.03%, V:0.05%
Weight (gr)	: 84 - 1421 gr

Included jointing compound inside the barrel to inhibit corrosion of aluminum

PRESS CONNECTOR (GAE)



Cable Size	: 2.5 - 500 mm ²
Material	: Copper
Finishing	: Tin Plated
Composition of Copper	: ≥ 99.92%
Electrical Conductivity	: ≥ 98%
Tensile Load	: ≥ 250N
Class	: A

SAINT-ELME SERIES LIGHTNING CONDUCTOR

Introduction to ESE (Early Streamer Emission)

Short reminder on ESE lightning conductor

- Simple rod equipped with a device reducing the excitation time
- **Better probability** to capture the descending tracer

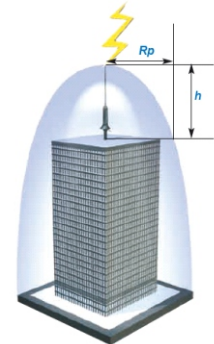
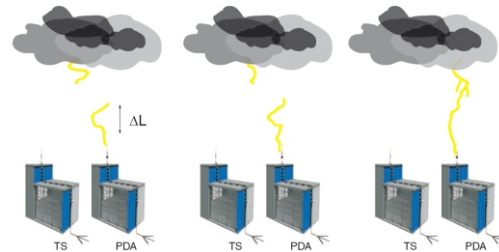

Radius of Protection

Radius of protection R_p are theoretically calculated following NF C 17-102

French standard and depending on

- Excitation advance time (in μs)
- Lightning conductor height h
- Level of protection (I, II, III or IV)

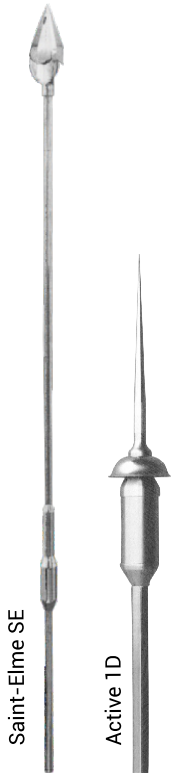

Rp	Active 1D 12				SE6				SE9				Active 1D 60 ; SE15			
	$\Delta T=12\mu s$				$\Delta T=15\mu s$				$\Delta T=30\mu s$				$\Delta T=60\mu s$			
H(m)	I	II	III	IV	I	II	III	IV	I	II	III	IV	I	II	III	IV
2	11	16	16	19	13	15	18	20	19	21	25	28	31	34	39	43
4	23	32	32	37	25	29	36	41	38	43	51	57	63	69	78	85
5	28	41	41	46	32	37	45	51	48	55	63	71	79	86	97	107
6	28	41	41	46	32	38	46	52	48	55	64	72	79	87	97	107
8	28	41	41	46	33	39	47	54	49	56	65	73	79	87	98	108
10	30	45	45	52	34	40	49	56	49	57	66	75	79	88	99	109
20	32	51	51	60	35	44	55	63	50	59	71	81	80	89	102	113
30	32	55	55	65	35	45	58	69	50	60	73	85	80	90	104	116
60	32	57	57	72	35	34	58	75	50	60	75	90	80	90	105	120

LIGHTNING COUNTER



Ordering Code	AFV1007CF
Classification	Type 1
Minimum shock discharge current $I_{imp\ min}$	1 kA - onde 10/350
Maximum shock discharge current $I_{imp\ max}$	100 kA - wave 10/350
Display	6 digits (0 à 999999)
Material	Polycarbonate case / 304L stainless steel flange
Fixing on conductor (specific flanges included)	Compatible with flat conductor 30x3.5mm max / round conductor $\varnothing 10mm$ max
Working temperature	-10°C à + 60°C
Relative Moisture	0% HR à 100% HR
Max operating altitude	4000 meters above sea level
Indice of protection	IP 65
Weight 0,500 kg	0,500 kg
Standards NF EN IEC 62561-6 Ed2	NF EN IEC 62561-6 Ed2

EARTHING EQUIPMENT



CONTROL JUNCTIONS

NF C 17- 100 and NFC 17-102 standards:

A control junction must be inserted on each down conductor to allow disconnection from its earth terminal. The 2F control junction, featuring very low impedance and perfect conductivity, is designed for easy installation and inspection

GIM GROUNDING IMPROVEMENT MATERIAL



GIM Ground Improving Material is an earthing backfill compound consisting of highly conductive materials, which increase the earthing system's efficiency. It is most useful for area with high soil resistance and also when the probability of erosion due to the flow of water exists.

4 POLE SURGE PROTECTION DEVICE

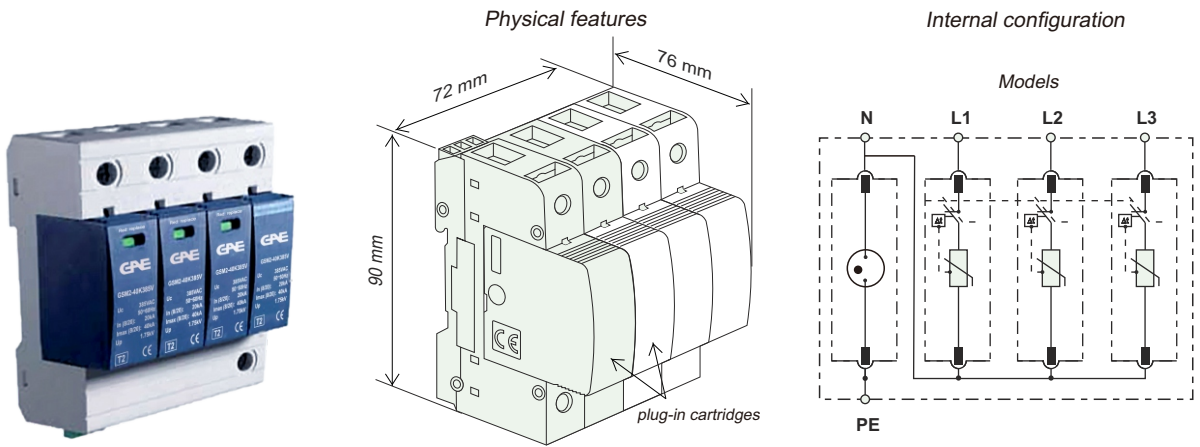

AVAILABLE IN:

	Model	Description	Code no.
Type 1+2 100kA 4 Pole	GSM12-100K320V-4PGM	SPD GSM12-100K320V-4PGM Class I+II 4P 100kA	707987
Type 2 65kA 4 Pole	GSM2-65K385V-4PGM	SPD GSM2-65K385V-4PGM Class II 4P 65kA	707989
Type 2 40kA 4 Pole	GSM2-40K385V-4PGM	SPD GSM2-40K385V-4PGM Class II 4P 40kA	707967
Type 2 20kA 4 Pole	GSM2-20K385V-4PGM	SPD GSM2-20K385V-4PGM Class II 4P 20kA	707969

2 POLE SURGE PROTECTION DEVICE

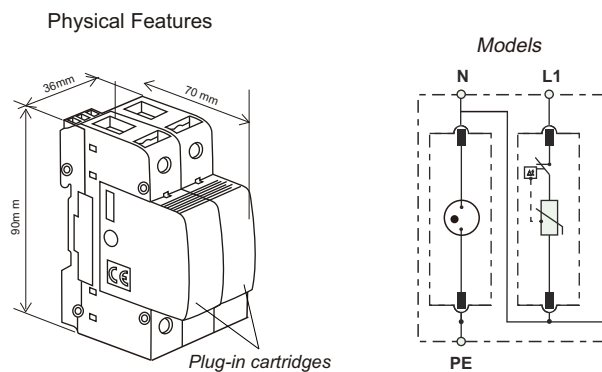

AVAILABLE IN:

	Model	Description	Code no.
Type 2 40kA 2 Pole	GSM2-40K385V-2PGM	SPD GSM2-40K385V-2PGM Class II 2P 40kA	707977
Type 2 20kA 2 Pole	GSM2-20K385V-2PGM	SPD GSM2-20K385V-2PGM Class II 2P 20kA	707979



PT GUNA ERA DISTRIBUSI

Affiliated company of PT Guna Elektro

www.gae.id

email: ged.info@gae.id

JAKARTA TIMUR 13930

Jl. Rawa Gelam II No. 8

Jakarta Industrial Estate Pulogadung

T (021) 4682 5050, F (021) 4682 4758

MEDAN 20157

Jl. Padang Golf Blok CC No. 15

Komp. CBD Polonia, Sukadamai

T (061) 4207 0007

SURABAYA 60293

Jl. Rungkut Industri I No. 29

Rungkut Industrial Estate

T (031) 849 3885-86, F (031) 841 6661